

# SC series

## Warning Light & Electric Horn Combinations



SC series can combine all of our warning light and electric horn products into a single combination model depending on your specific needs

### SC1

The budget model of small-sized warning light and electric horn combinations

- Protection rating : IP44

#### Specification for Standard Model

- Standard combination includes S100R products combination with SRN (same as pictured to the left)

#### Technical Diagram

(Units : mm)



SC1

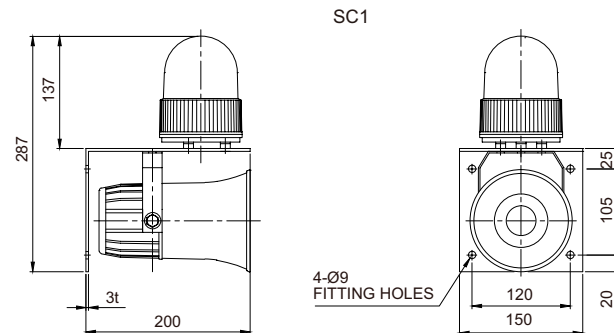

#### Customization

- Warning light : Select one from S100 series (Please refer to page 63-69) for the combination
- Electric horn : Select one from SN, SRN, SEN15/ 25 (Please refer to page 383-384) for the combination

### SC2

Most commonly used standard-sized warning light and electric horn combination model

- Protection rating : IP44

#### Specification for Standard Model

- Standard combination includes S125U products combined with the SEN15 (Same as pictured to the left)

#### Technical Diagram

(Units : mm)



SC2

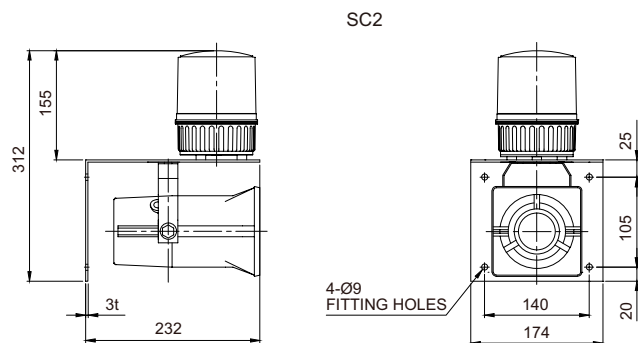

#### Customization

- Warning light : Select one from S125 series (Please refer to page 70-76) for the combination
- Electric horn : Select one from SN, SRN, SEN15/25 (Please refer to page 383-384) for the combination

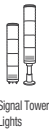

# SC series

## Warning Light & Electric Horn Combinations



### SC3

Waterproof, dustproof type warning light and electric horn combinations

- Protection rating : IP56



#### Common Specifications

- Combination of SH1-2T and signal horn SEWN30L(Same as pictured to the left)



#### Technical Diagram

(Units : mm)



SC3

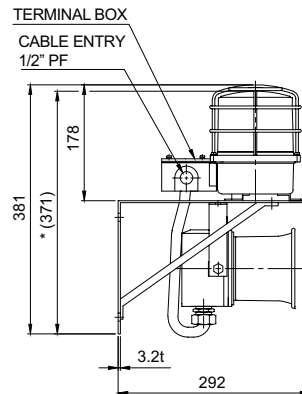

SC3

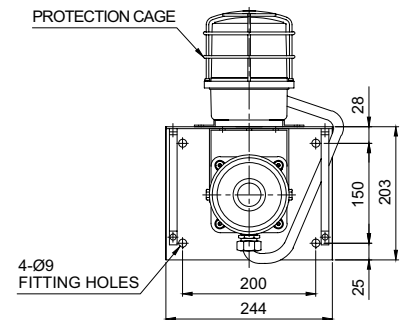

\* (371) represents SC3 size without protection cage.



#### Customization

- Warning light : Select between models SH1P-2T and SH2P-2T series (Please refer to page 153-159)
- Electric horn : Choose one model among SEWN30L/50L, SEHN25 and SEHN50 (Please refer to page 179-174)
- Stainless steel bracket



#### Standard Model Number

<b>SC1</b>	-	<b>220</b>	-	<b>R</b>
[Model number]		[Voltage]		[Color]
<ul style="list-style-type: none"> <li>• SC1 (S100R+SRN)</li> <li>• SC2 (S125U+SEN15)</li> <li>• SC3 (SH1P-2T+SEWN30L)</li> </ul>		<ul style="list-style-type: none"> <li>• 12-DC12V</li> <li>• 24-DC24V</li> <li>• 110-AC110V</li> <li>• 220-AC220V</li> </ul>		<ul style="list-style-type: none"> <li>• R-Red</li> <li>• A-Amber</li> <li>• G-Green</li> <li>• B-Blue</li> </ul>



#### Ordering Specification

<b>SC3</b>	-	<b>( SH1P-2T</b>	-	<b>R</b>	+	<b>SEWN30L</b>	-	<b>WS</b>	)	-	<b>220</b>
[Model number]		[Light type]		[Color]		[Horn type]		[Sound]			[Voltage]
<ul style="list-style-type: none"> <li>• SC1</li> <li>• SC2</li> <li>• SC3</li> </ul>		<ul style="list-style-type: none"> <li>• Select 1 model among S100 series</li> <li>• Select 1 model among S125 series</li> <li>• Select 1 model among SH1P-2T and SH2P-2T series</li> </ul>		<ul style="list-style-type: none"> <li>• R-Red</li> <li>• A-Amber</li> <li>• G-Green</li> <li>• B-Blue</li> </ul>		<ul style="list-style-type: none"> <li>• Select 1 model among SN, SRN and SEN15/25</li> <li>• Select 1 model among SRN and SEN15/25</li> <li>• Select 1 model among SEWN30L/50L and SEHN25/50</li> </ul>		<ul style="list-style-type: none"> <li>• WS -Warning sounds</li> <li>• WP -Special warning sounds</li> <li>• WM -Melodies</li> <li>• WA -Alarms</li> <li>• WV -Customizable voices</li> </ul>		<ul style="list-style-type: none"> <li>• 12-DC12V</li> <li>• 24-DC24V</li> <li>• 110-AC110V</li> <li>• 220-AC220V</li> </ul>	

\* Light sources can be selected among LED revolving, LED steady/flashing, xenon strobe and bulb revolving type.